



Precision Electrospinning Solutions
Advanced Technology for Ultra-Fine Fiber Production



made in Germany



- Electrospinning technology produces ultra-fine fibers that closely mimic natural structures, making it especially valuable in the medical field. In tissue engineering, electrospun nanofibers serve as scaffolds that support cell growth and regeneration, aiding in the development of artificial tissues and skin. These fibers can be engineered to degrade at controlled rates and infused with growth factors, promoting faster cell healing and integration.
- For wound care, electrospun dressings offer breathability, high absorbency, and antimicrobial protection, creating an optimal healing environment. Advanced wound dressings use these fibers to manage moisture while delivering medications directly to the wound site, reducing infection risk and improving recovery times. Additionally, electrospun fibers play a growing role in drug delivery, where they are used to release medications gradually over time. This controlled-release capability is especially beneficial in chronic treatments, as it reduces dosing frequency and maintains therapeutic levels.
- Electrospinning's potential in medical devices is expanding as well, from smart dressings that respond to environmental changes to bioactive stents that support vascular repair. The technology's precision and biocompatibility are driving new healthcare solutions that improve patient outcomes, demonstrating electrospinning's transformative impact in medicine.



- Electrospinning is a transformative technology in biomedical science, particularly in tissue engineering and drug delivery, due to its ability to produce ultra-fine fibers that mimic natural extracellular matrices.
- In **tissue engineering**, electrospun nanofibers create scaffolds that promote cell adhesion, proliferation, and differentiation, making them ideal for applications like neural and muscle tissue regeneration. In **wound healing**, these fibers can be infused with growth factors or antimicrobial agents, facilitating moisture management and localized therapy.
- In **drug delivery**, electrospun fibers provide controlled and sustained release of therapeutic agents, enhancing patient compliance and reducing side effects. They can be engineered for targeted therapy and combined therapies, addressing complex conditions like cancer.
- The advantages of electrospinning include customization of fiber properties, scalability for industrial production, and the use of biocompatible, biodegradable materials. Overall, electrospinning stands at the forefront of innovative medical therapies, offering promising solutions for improving patient outcomes.

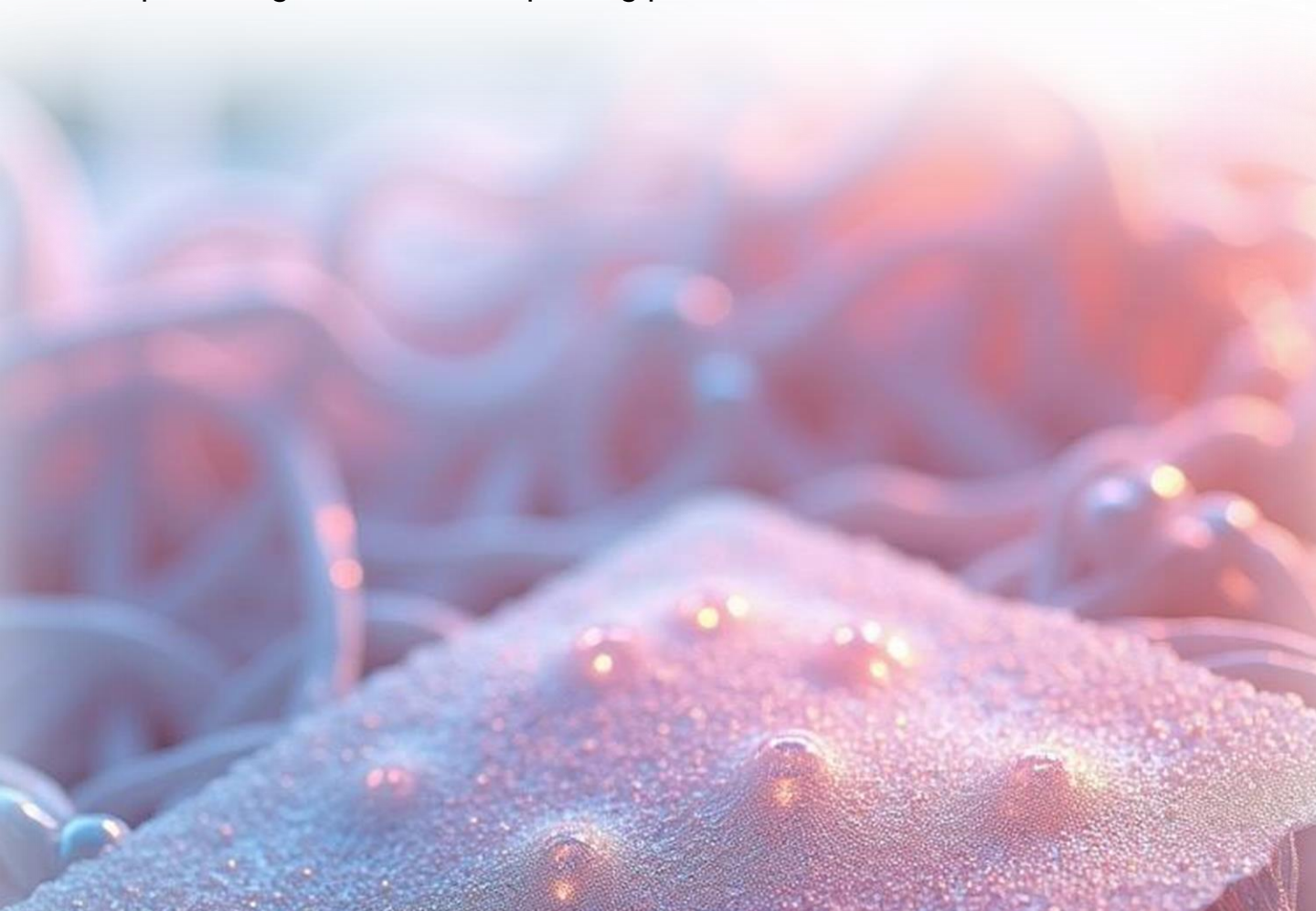

Advancing Tissue Engineering with Electrospinning

Tissue engineering is a groundbreaking field in biomedical science focused on creating biological substitutes to repair or replace damaged tissues. It combines principles from biology, materials science, and engineering to develop solutions for regenerating or restoring tissue function, with applications spanning wound healing, organ repair, and cell-based therapies. At the heart of tissue engineering is the development of **scaffolds**—three-dimensional structures that mimic the extracellular matrix (ECM), the natural framework surrounding cells. These scaffolds support cell attachment, growth, and differentiation, providing an environment that promotes tissue formation. The ideal scaffold should replicate the physical and biological properties of native tissues, allowing cells to thrive and encouraging natural integration with the surrounding environment.



Electrospinning is a highly effective technique for creating these scaffolds, as it produces nanofibers that closely resemble the fibrous structure of the ECM. Electrospun fibers can be customized in diameter, alignment, and porosity, making them particularly suitable for different types of tissues, such as muscle, nerve, bone, and skin. Additionally, electrospun scaffolds can be made from biodegradable polymers, which gradually degrade as new tissue forms, leaving behind only the regenerated tissue. They can also be loaded with growth factors, proteins, or drugs to facilitate healing and cell growth, allowing for targeted, sustained release at the site of regeneration. This versatility and precision in scaffold design make electrospinning a powerful tool in tissue engineering, advancing the potential for regenerative treatments that can address patient-specific needs and improve outcomes in tissue repair and reconstruction.

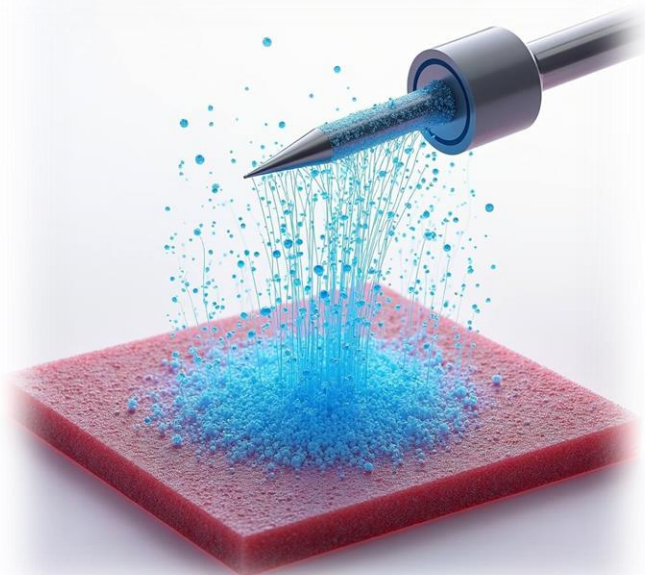

Enhanced Drug Delivery Systems Through Electrospinning

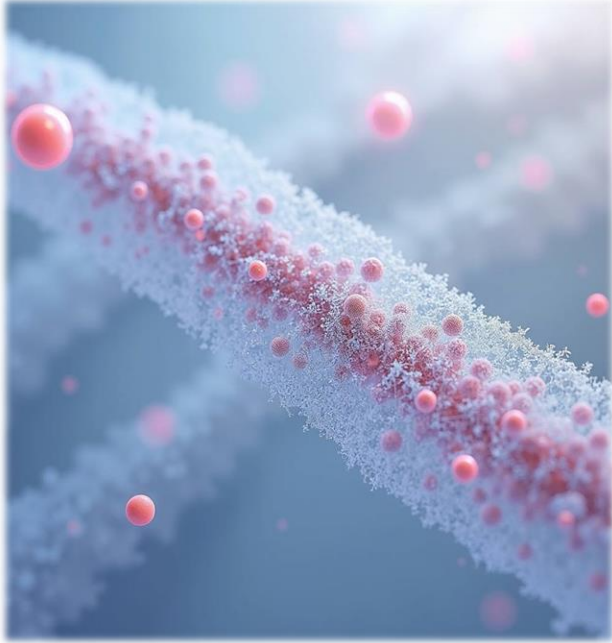

Drug delivery is a critical aspect of modern medicine, focused on ensuring that therapeutic agents are delivered effectively and efficiently to the targeted site in the body. The goal is to achieve controlled, sustained, and localized release of drugs, minimizing side effects and maximizing therapeutic effects. Traditional methods of drug delivery often face challenges related to poor bioavailability, short half-lives, or systemic side effects. To address these issues, advanced drug delivery systems are being developed to improve precision and effectiveness. **Electrospinning** plays a key role in this field, offering a method for creating **nanofiber-based drug delivery systems** that can encapsulate drugs and provide controlled release over time.

Electrospun nanofibers can be engineered to carry a wide range of drugs, from small molecules to proteins and nucleic acids, while providing a sustained and controlled release profile. The high surface area and porosity of electrospun fibers make them ideal for loading drugs and ensuring efficient release. Furthermore, the fiber morphology can be tailored to respond to specific environmental stimuli, such as changes in pH or temperature, which enables targeted drug release at specific locations within the body. This level of precision is particularly beneficial in treating chronic conditions, such as cancer or diabetes, where long-term, localized drug delivery is crucial. With electrospinning, researchers are able to design innovative drug delivery systems that not only improve efficacy but also reduce the need for frequent dosing, enhancing patient compliance and overall treatment outcomes.



Advancing Wound Healing



Electrospinning plays a pivotal role in advancing **wound healing** therapies by providing highly effective and customizable materials for wound dressings. Electrospun nanofiber-based scaffolds mimic the structure of the natural extracellular matrix (ECM), offering a supportive environment for cell growth and tissue regeneration. These scaffolds are particularly beneficial in chronic wound care, as they allow for moisture retention, protect against infection, and promote faster healing. The high surface area and porosity of electrospun fibers also facilitate gas exchange, which is crucial for wound healing, and help in the controlled release of therapeutic agents, such as growth factors or antibiotics, directly at the site of injury.

In addition to their structural benefits, electrospun materials can be tailored to meet the specific needs of various types of wounds, including diabetic ulcers, burns, and surgical wounds. The fibers can be infused with antimicrobial agents, anti-inflammatory drugs, or bioactive compounds to accelerate healing and prevent infection. Furthermore, electrospinning allows for the creation of dressings that are lightweight, flexible, and comfortable, improving patient compliance and the overall effectiveness of the treatment. With the ability to adjust the properties of the fibers, electrospinning offers a versatile, cutting-edge solution for improving wound care and accelerating tissue repair.



Innovative Solutions for Nerve Regeneration with Electrospinning

Electrospinning plays a crucial role in nerve tissue engineering by providing scaffolds that promote the regeneration of damaged nerves. These electrospun nanofibers mimic the natural extracellular matrix of nerves, offering a supportive and aligned structure for nerve cells to attach, grow, and differentiate. The fibers guide the direction of nerve regeneration, ensuring that the regenerated tissue restores proper nerve function. In addition to their structural benefits, electrospun scaffolds can be functionalized with bioactive molecules, such as growth factors or neurotrophins, which stimulate nerve repair and accelerate recovery. This technology has significant potential in treating nerve injuries, spinal cord damage, and neurodegenerative diseases, offering hope for more effective, targeted treatments to restore nerve function and improve quality of life.



Enhancing Medical Implants with Electrospun Nanofiber Coatings

Electrospinning technology is increasingly being used to create advanced **coatings** for medical implants, offering numerous advantages in improving implant integration, reducing complications, and enhancing healing. Electrospun nanofibers can be applied as bioactive coatings on implants such as **orthopedic devices**, **stents**, and **prosthetics** to promote better tissue integration and accelerate the healing process. These nanofibers mimic the natural extracellular matrix, providing a more favorable environment for cell attachment and tissue growth, ensuring that the body more effectively accepts the implant. Additionally, electrospun coatings can be engineered to release **antimicrobial agents**, **growth factors**, or **anti-inflammatory compounds** over time, preventing infection, reducing inflammation, and stimulating tissue repair at the implant site.

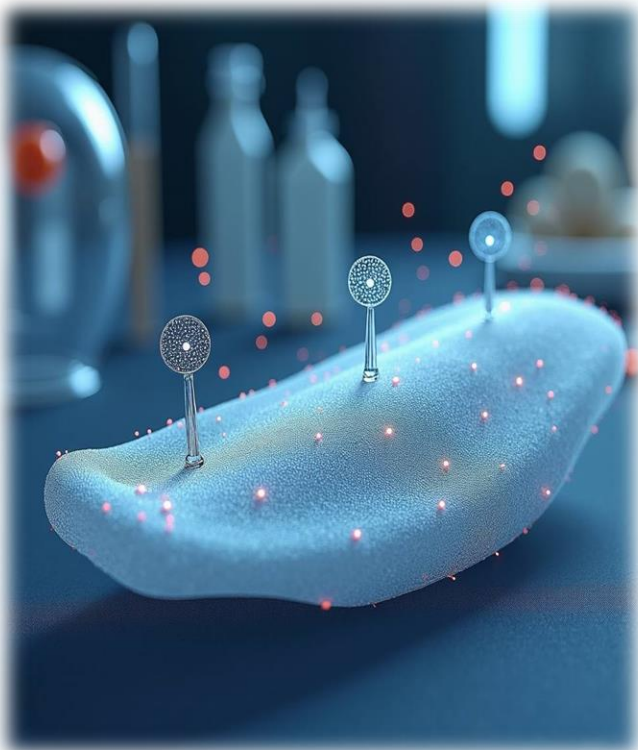

Furthermore, electrospun coatings can be designed to offer specific mechanical properties that match the implant material, such as flexibility, porosity, or strength, ensuring that the implant remains stable and functional. By tailoring the nanofiber structure and bioactive content, electrospinning enables the creation of coatings that are patient-specific, enhancing the long-term success of medical implants. Whether for joint replacement, cardiovascular stents, or dental implants, electrospun nanofiber coatings provide a promising solution to improve the performance, safety, and longevity of medical devices, reducing the risk of complications and improving overall patient outcomes.

Advancing Cardiovascular Tissue Engineering with Electrospun Nanofibers

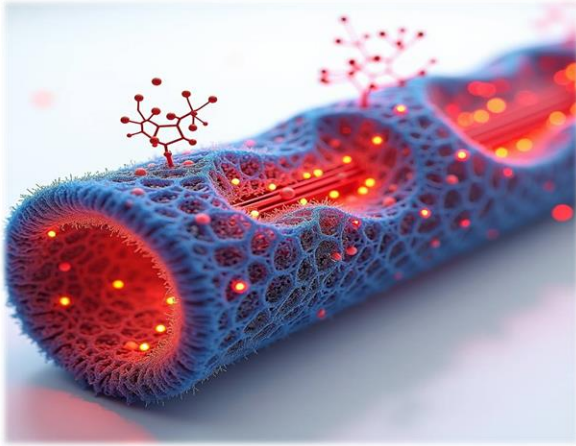

Electrospinning technology plays a crucial role in **cardiovascular tissue engineering** by creating scaffolds that support the regeneration of heart valves, blood vessels, and other vascular tissues. The nanofiber scaffolds produced through electrospinning mimic the structure of natural blood vessels, providing a supportive environment for cell attachment, growth, and differentiation. These scaffolds are highly porous and flexible, making them ideal for use in tissues that require both strength and elasticity, such as blood vessels. By promoting endothelial and smooth muscle cell proliferation, electrospun fibers help to restore the integrity and functionality of cardiovascular tissues, improving outcomes in procedures like vascular grafts or heart valve replacements.

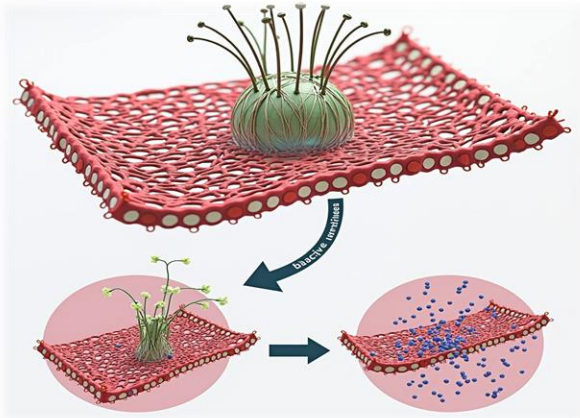

Moreover, electrospun scaffolds can be functionalized with bioactive molecules such as **vascular endothelial growth factor (VEGF)** to stimulate blood vessel formation or other growth factors to enhance tissue repair. This allows for a controlled release of therapeutic agents that further support healing and tissue regeneration. The high surface area and customizable properties of electrospun nanofibers make them an excellent choice for creating scaffolds tailored to specific cardiovascular applications, paving the way for more effective and durable solutions in cardiovascular medicine.



Horizontal and Vertical Scanning Systems

The **horizontal and vertical scanning systems** are responsible for controlling the movement of the spinneret (the part where the polymer solution is extruded) during electrospinning.

By allowing precise control in both directions, these scanning systems ensure an even distribution of fibers across the collector.

This coordinated movement is crucial for creating uniform nanofiber mats, especially when producing larger samples or materials that require specific alignments.

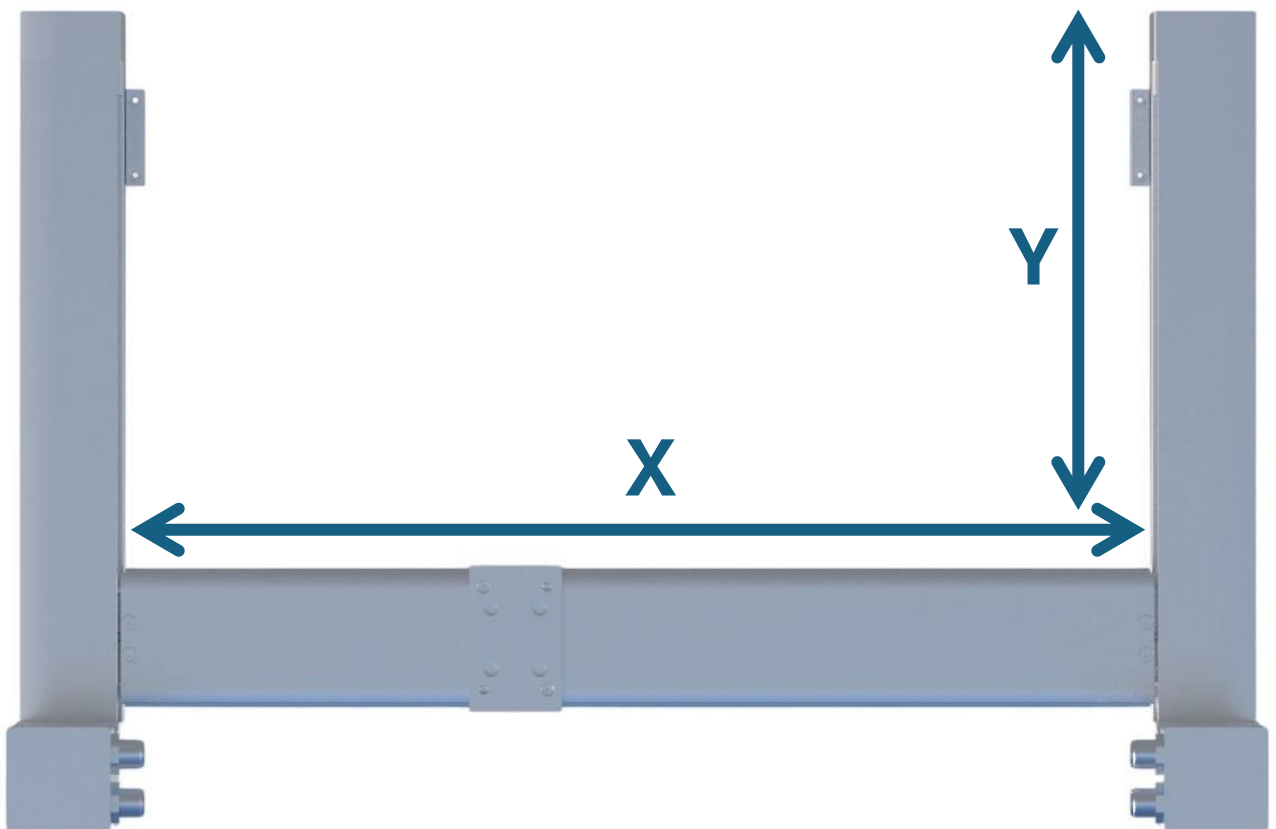

Horizontal Scanning

The horizontal scanning system moves the spinneret laterally across the collector. This motion is particularly useful for distributing fibers evenly over a wide surface area, which is essential in applications like wound dressings, where consistent coverage is necessary.

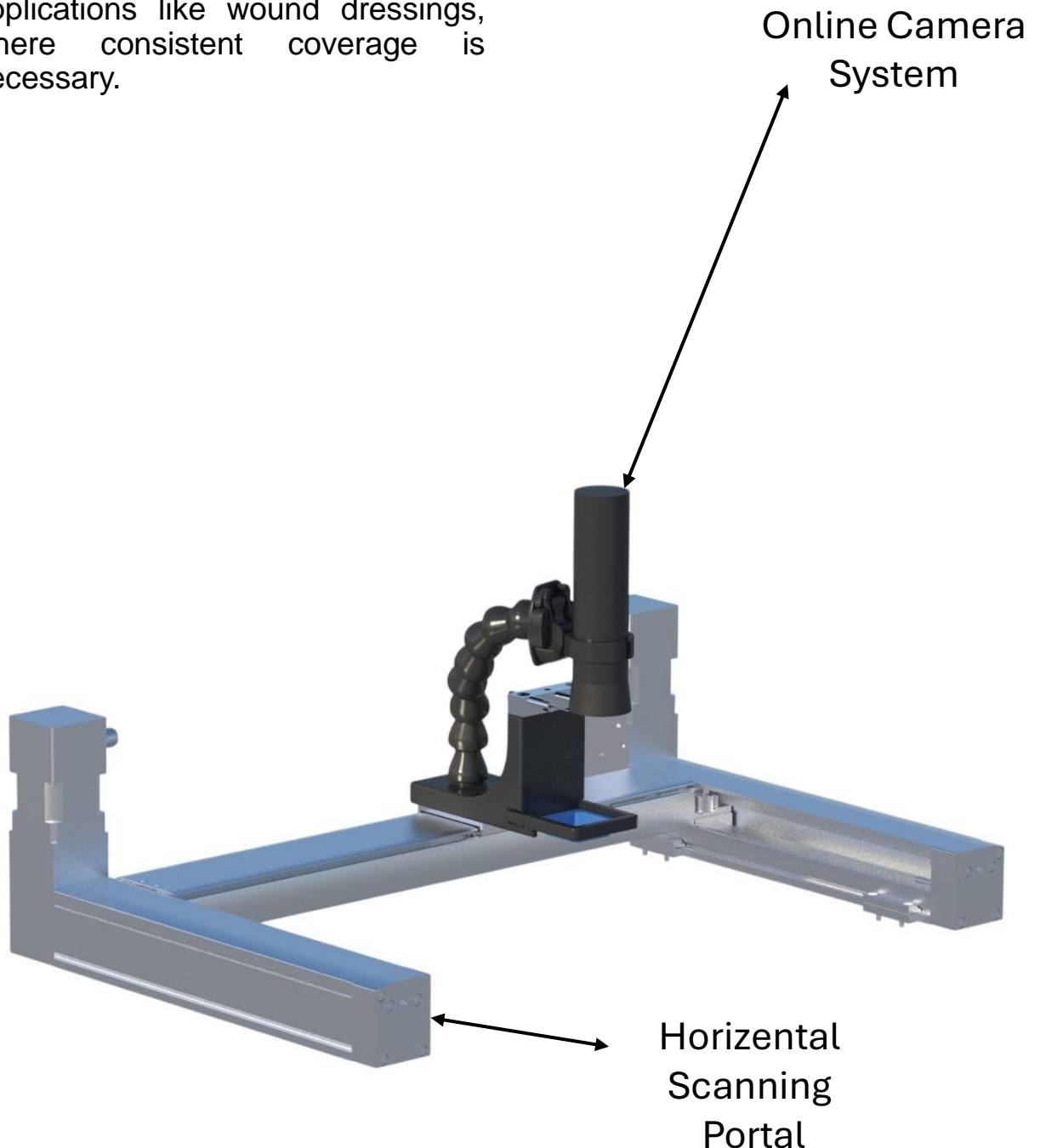

Vertical Scanning

- The vertical scanning system adjusts the spinneret's height, controlling the distance between the spinneret and the collector. This distance impacts fiber thickness, morphology, and stability, as it regulates the stretching and deposition of fibers. In setups where vertical alignment is required—such as in certain biomedical scaffolds—this control enables more precise fiber structures.

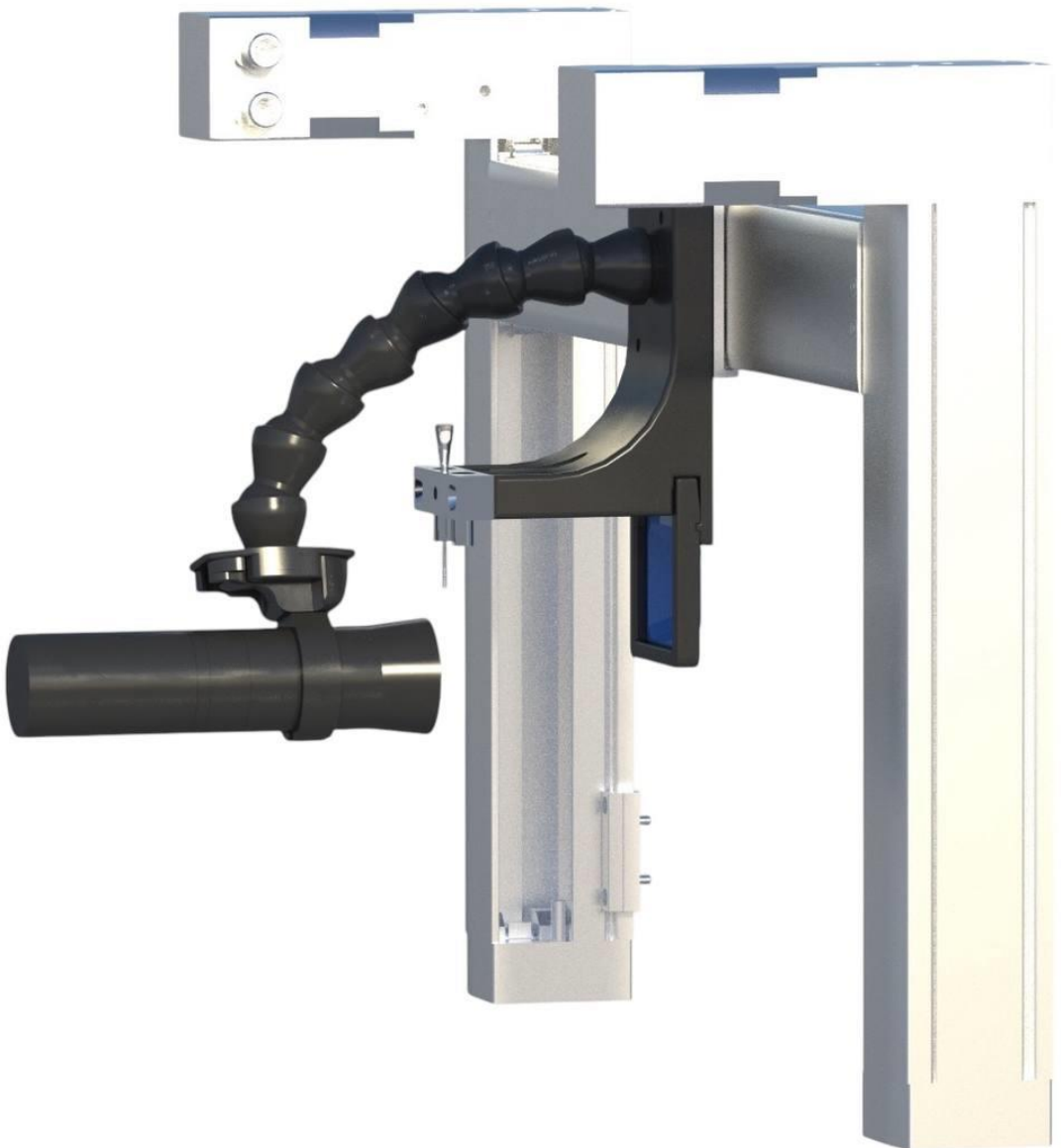

Collector

- The **collector** is the target surface where fibers are deposited, and it can significantly influence the final structure and properties of the electrospun fibers. Collectors come in various forms, including flat, rotating, and patterned, each providing distinct benefits:
- **Flat Collectors:** These produce randomly oriented fiber mats, commonly used in filtration and general wound care applications. The flat surface allows fibers to deposit in a random fashion, creating a non-woven mat with high porosity.
- **Rotating Collectors:** Rotating drum or cylinder collectors are used to align fibers in a more organized pattern, which is beneficial for applications requiring high tensile strength and directional alignment, such as tissue engineering scaffolds or reinforced composite materials.
- Together, the scanning systems and collector enable precise control over the fiber deposition process, allowing for customizable and reproducible nanofiber products. These components are key to achieving the specific fiber characteristics required in advanced applications, particularly in the medical field where uniformity and structural integrity are critical for success.

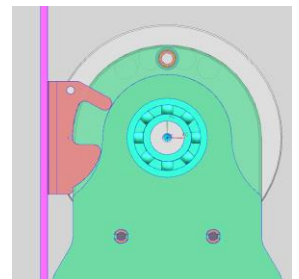
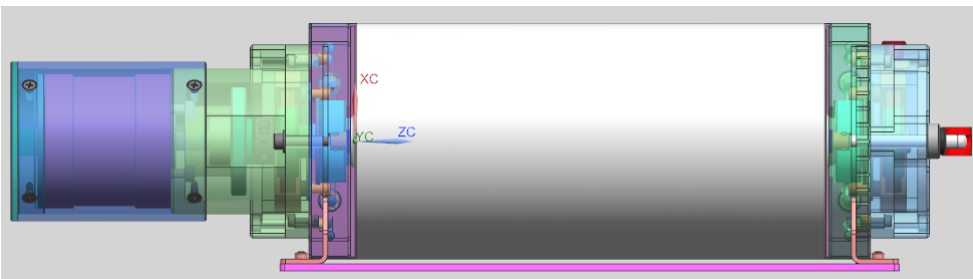

High-Speed Rotating Collector

Your high-speed rotating collector, capable of up to 10,000 RPM with minimized vibration, enables precise fiber alignment and uniformity, crucial for applications requiring strong, aligned fibers.

In biomedical uses like tissue engineering and vascular grafts, aligned fibers mimic natural tissue structure, supporting cell growth and integration. For industrial uses, such as filtration and battery separators, high-speed rotation ensures even fiber distribution, enhancing material performance and durability.

The minimized vibration feature ensures stability, reliability, and equipment longevity, making your system a versatile solution for advanced fiber applications across medical and industrial fields.



Elevating Fiber Quality

A high-speed rotating collector with precise control and minimal vibration greatly improves fiber quality by ensuring uniform alignment, optimized morphology, and enhanced mechanical strength.

This consistency benefits applications where fiber orientation and surface quality are critical, such as in tissue engineering, durable textiles, and filtration.

The smooth, defect-free fibers it produces support better cell attachment and controlled drug delivery, while scalability and versatility make it ideal for both specialized and industrial-scale production, ensuring reliable, high-performance fibers across diverse fields.

Our high-speed rotating collector enables the production of ultra-fine fibers with diameters as thin as 20 nanometers, ensuring exceptional precision and consistency.



Online Camera System

The online dynamic camera system in your electrospinning equipment provides real-time monitoring and recording capabilities, enabling precise observation of the Taylor cone formation on-screen. This camera system is crucial for optimizing fiber quality, as the stability and shape of the Taylor cone directly impact fiber diameter and consistency. By allowing operators to dynamically monitor the process, the system enables immediate adjustments to parameters like voltage, solution flow rate, and distance, ensuring optimal conditions for consistent fiber production. The ability to record the process also aids in quality control and process documentation, making the camera system an essential tool for maintaining high production standards.

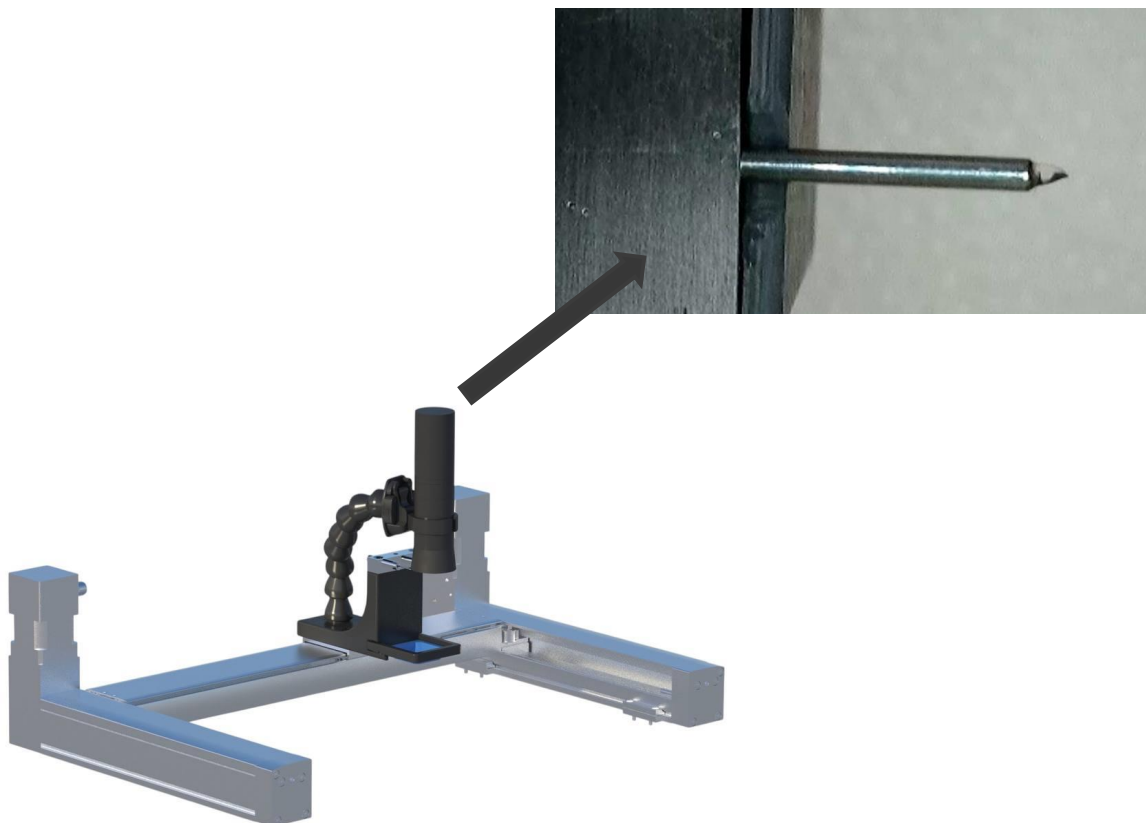

Pumps

Your electrospinning system incorporates **high-precision pumps** designed for exceptional material delivery control. Each pump features a **stepper motor**, spindle, linear guideway, syringe holder, and replaceable syringes. With a resolution of **25,600 steps per revolution**, the stepper motor ensures smooth and precise movements for accurate dispensing, which is critical for uniform fiber production.

The system supports **metering syringes from 0.05 ml to 100 ml**, allowing for flexibility in handling various material volumes. By positioning the pumps outside the electrospinning chamber, the material remains separate, preventing contamination and preserving integrity. Additionally, extra pump units can be installed on both the horizontal and vertical sides, providing customizable setups that prioritize accuracy and versatility for high-precision applications.

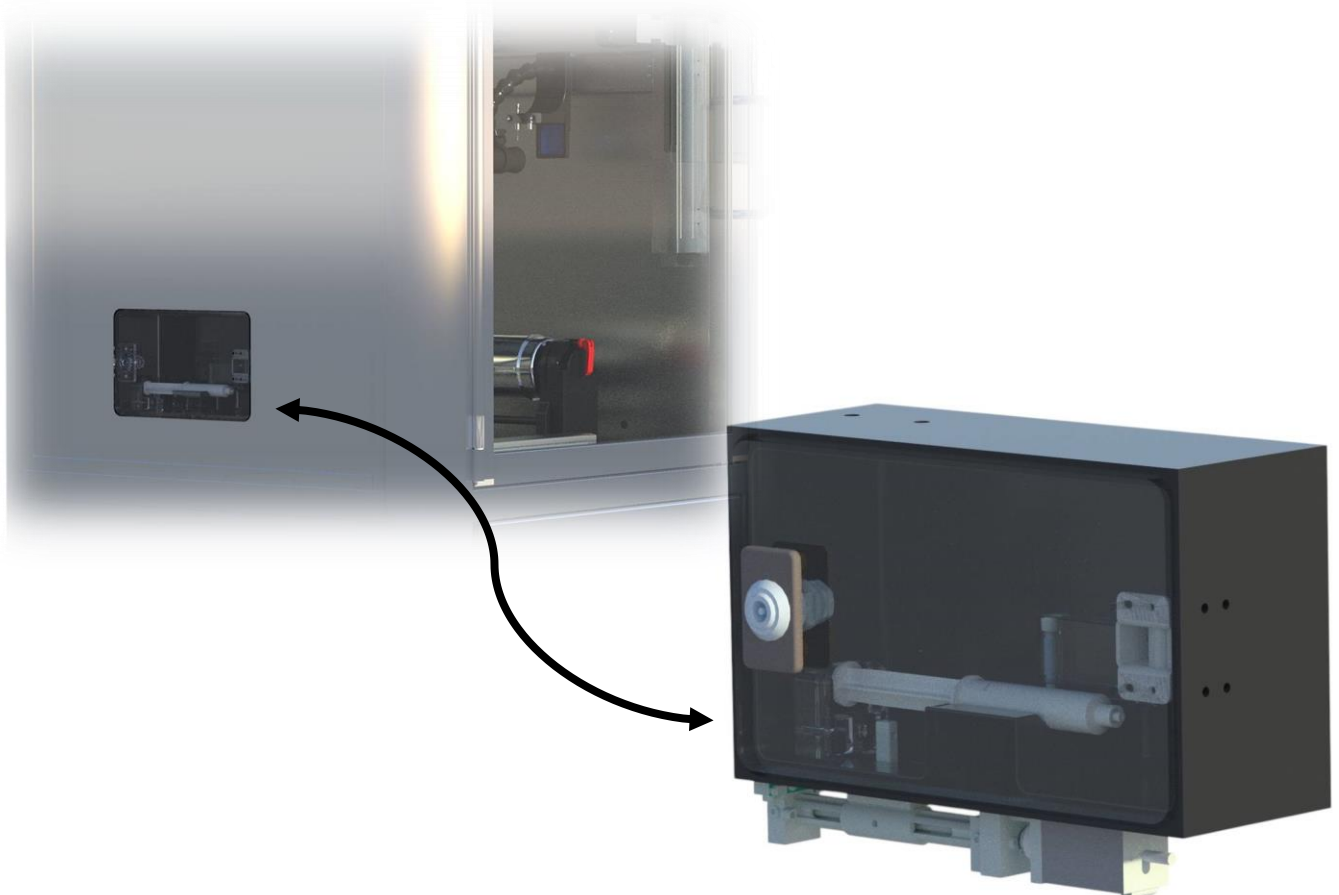

Control Panel

- Your electrospinning machine is equipped with a **12-inch Siemens SIMATIC HMI Unified Comfort Panel**, designed to provide intuitive and powerful control over the entire process. This advanced panel, with its capacitive multitouch display, offers seamless navigation, allowing operators to interact with the machine through a responsive, tablet-like experience. The SIMATIC HMI series, available in sizes ranging from 7 to 21.5 inches, provides the flexibility to scale visualizations to meet various operational needs.
- With **vector-based visualization** capabilities, the panel delivers sharp, clear graphics that adapt smoothly to any screen size, ensuring an optimal user interface for monitoring and adjusting machine parameters. The software is robust and versatile, with the option to expand functionality by installing additional apps, making it easy to customize the system to meet specific requirements. This flexibility and strength of control allow for precise adjustments in real-time, enhancing the reliability and accuracy of the electrospinning process.



get in touch!

Our electrospinning machines are crafted to redefine the standards of nanofiber production, combining advanced engineering with robust performance.

Built for industries demanding precision, consistency, and scalability, our technology supports applications in healthcare, filtration, energy, textiles, and beyond.

With a focus on quality and adaptability, our machines enable the controlled creation of nanofiber structures that meet complex project requirements with ease.

Whether you're innovating in material science or enhancing product performance, our electrospinning solutions are designed to streamline your production processes and elevate your capabilities. Discover how our expertise and cutting-edge technology can advance your vision.

**Am Rollefer Berg 56,
52078,
Aachen, Germany
www.epcotec.de
nano@epcotec.de**



EPCOTEC

